



RE THERM

GRE060DW/EW

Regeneration oven
 to reheat refrigerated
 food (+3°C)

CONSTRUCTION FEATURES

- Tightness chamber with radiused corners
- Total thermic insulation with rock or glass wool
- Long lasting front seals made up of food grade of high heat resistance
- Removable side racks to facilitate cleaning
- Internal drain for easy cleaning
- Ventilated heating provided by high efficiency protected heating elements
- Snap-shut door
- Adjustable feet
- Easy access to facilitate maintenance and repair
- Double low-emission glass door with internal ventilation
- Condensation drip tray under the door and connected to the oven drainage system.

FUNCTIONAL FEATURES

- Electronic control panel with digital display (D or electronic with LCD touch-screen display (E)
- Simplified, user-friendly controls
- Periodic reversal of direction of rotation of the fan for better air distribution
- Automatic stopping of fans when the door is opened
- End-of-cycle buzzer
- Chamber with safety thermostat
- Operating temperature 30°C ÷ 160°C
- The regeneration program can be divided into different phases
- Self-diagnosis system
- MultiLevel function: Combi is able to manage different dishes with different cooking times or temperatures (only for E version)
- IdealWarm function: the intelligent temperature decrease in the cavity at the end of the cooking cycle allows perfect warm holding
- Climachef system
- PadLock: key lock system with password
- ProTime system allows you to set the date and the time you want the oven to preheat or start working
- Glazed door plus lighting
- Removable GN2/3 tray racks
- EcoWash self-cleaning system



OPTIONS & ACCESSORIES

- | | | |
|--|--|--|
| <input type="checkbox"/> Supports | <input type="checkbox"/> Openable inside glass of the door | <input type="checkbox"/> Water filter system |
| <input type="checkbox"/> Single-point core probe | <input type="checkbox"/> Built-in sliding kit | <input type="checkbox"/> Grids |
| <input type="checkbox"/> Multipoint core probe | <input type="checkbox"/> Wall brackets kit | <input type="checkbox"/> Trays |
| <input type="checkbox"/> Needle core probe, thin | <input type="checkbox"/> Stacking kit | <input type="checkbox"/> Sound silencer |
| <input type="checkbox"/> External hand shower | <input type="checkbox"/> Integrated water storage tank | <input type="checkbox"/> Air condensation hood |
| <input type="checkbox"/> Integral quenching system | <input type="checkbox"/> Usb port | <input type="checkbox"/> One Touch Software (only for E version) |
| | <input type="checkbox"/> SpeedGrade fan speed adjustment | <input type="checkbox"/> Opposite side opening |
| | | <input type="checkbox"/> Door lock with key |



moduline

TECHNICAL INSTALLATION DIAGRAM

- Electricity supply cable inlet 
- Safety vent humidity 
- Chamber drain 
- Softened water inlet 
- Adjustable vent for excess humidity 

Important - Drawing and dimensions refer to the standard version. They may change with the addition of accessories or options.

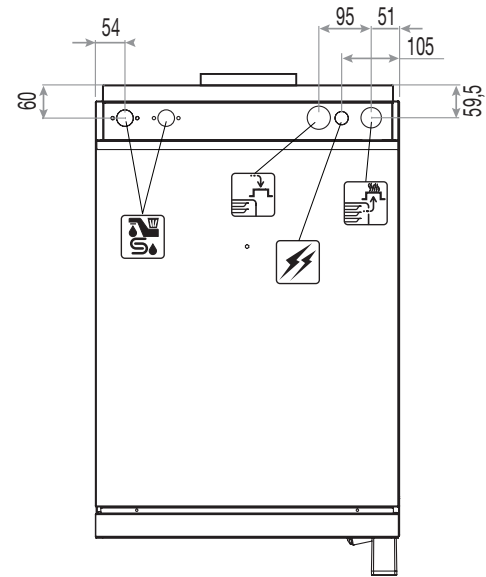
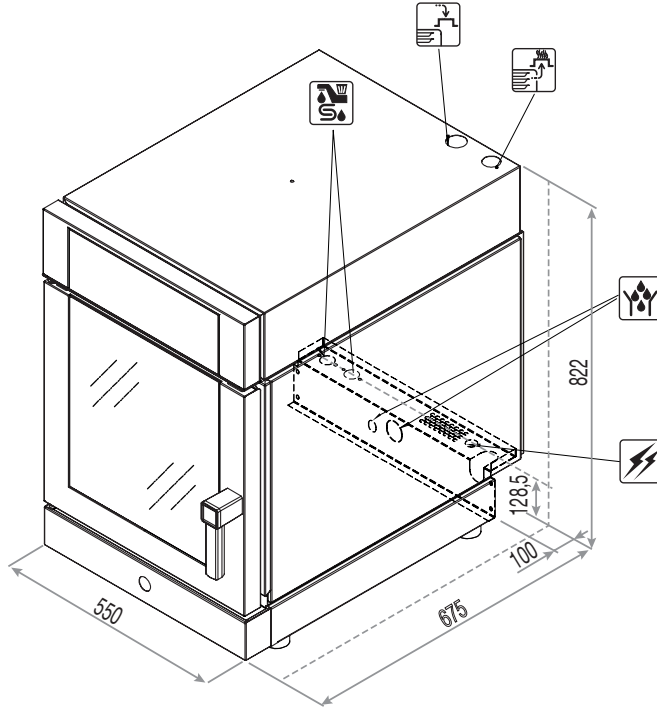

Overall dimensions (W x D x H) - mm	550 x 675 x 822 h	Product max capacity [Kg]	10
Trays capacity	6 x GN 2/3	Total input [kW]	3,6 (230V)
Plates capacity	6 Ø 200-320	Amps. [A]	15,7 (230V)
Distance [mm]	64	Water pressure [kPa]	150 ÷ 500
Power supply	AC 220-240V 50/60Hz	Net weight [Kg]	65
Working temperature [°C]	30 ÷ 160		

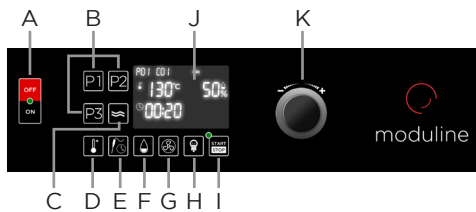

D Version

- A ON/OFF switch
- B Pre-set program keys
- C Holding function key
- D Cavity temperature control key
- E Time / core probe control key
- F Cavity humidity control key
- G Fan speed control key (optional)
- H Cavity light key
- I Start/stop key
- J Display
- K Encoder knob

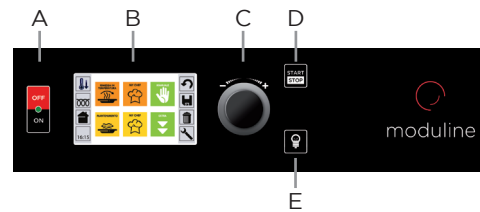

E Version

- A ON/OFF switch
- B Display Touch Screen
- C Setting knob and select "ENTER"
- D "START/STOP" button
- E Chamber light button

MODULINESRL

Via dell'Industria 11, Z.I. San Giacomo di Veglia 31029 Vittorio Veneto (TV) - ITALY
tel. +39 0438 5063 - fax +39 0438 912 323 - info@moduline.it - www.moduline.it